

Qualified for Automotive Applications
Wide Input Voltage Range: 3.2V-50V
Low Shutdown Current 3.7uA
Low Quiescent operating Current: 450uA
Adjustable Switching Frequency: 100KHz to 2.2MHz
Integrated Frequency Dithering for EMI Mitigation
External Frequency Synchronic
External Compensation
Supports additional Slope Compensation
22ms Internal Soft-start Time
Integrated Protection Feature

- Constant Peak-Current Protection Threshold Over Input Voltage
- Output Overvoltage Protection
- Adjust Under-Voltage Lockout
- Optional Hiccup Over Load Protection
- Thermal Shutdown Protection:165°C

MSOP-8L(3mm*3mm) Package

The SCT81620 device is a wide input, non-synchronous boost controller. The Device can be used in Boost, SEPIC and Flyback converters and topologies.

The switching frequency of the SCT81620 device can be adjusted to any value between 100kHz and 2.2MHz by using a single external resistor or by synchronizing it to an external clock. Current mode control provides superior bandwidth and transient response in addition to cycle-by-cycle current limiting.

Muti-output Flyback
LED Bias Supply
Portable Speaker Supply
Battery Powered Boost/Flyback/SEPIC application

Over operating free-air temperature range unless otherwise noted

PARAMETER	DEFINITION	MIN	MAX	UNIT
V _{IN}	Input voltage range	3.2	50	V
V _{CC}	VCC voltage range	3.2	6.1	V
T _J	Operating junction temperature	-40	125	°C

PARAMETER	DEFINITION	MIN	MAX	UNIT
V _{ESD}	Human Body Model(HBM), per ANSI-JEDEC-JS-001-2014 specification, all pins	-2	+2	kV
	Charged Device Model(CDM), per ANSI-JEDEC-JS-002-2014 specification, all pins	-1	+1	kV

PARAMETER	THERMAL METRIC	MSOP-8	UNIT
R	Junction to ambient thermal resistance ⁽¹⁾	132.8	°C/W

SYMBOL	PARAMETER	TEST CONDITION	MIN	TYP	MAX	UNIT
t _{ON_MIN}	Minimum on-time	Fsw=400kHz		250		ns

Protection

V

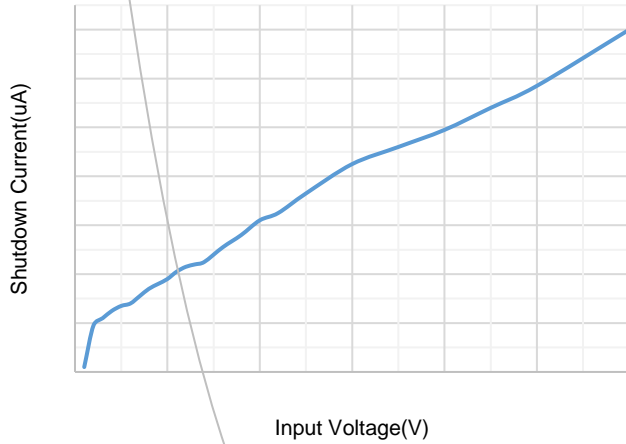

Figure 1. ISD vs Input Voltage

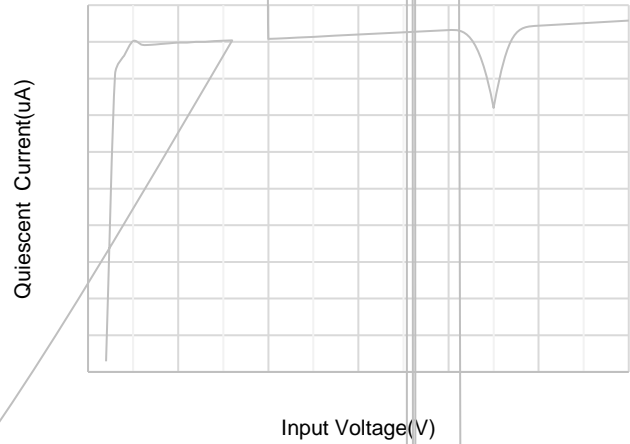

Figure 2. IQ vs Input Voltage

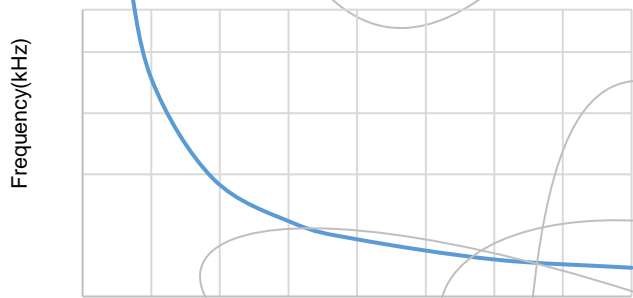

Figure 3. Switching Frequency vs RT

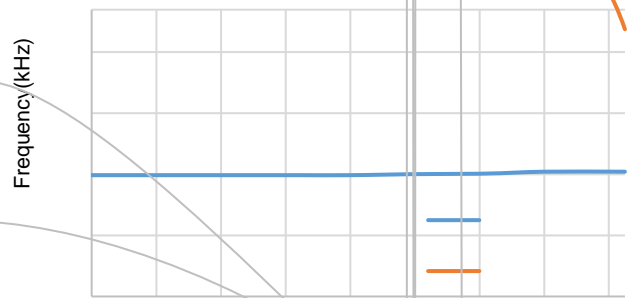

Figure 4. Switching Frequency vs Temperature

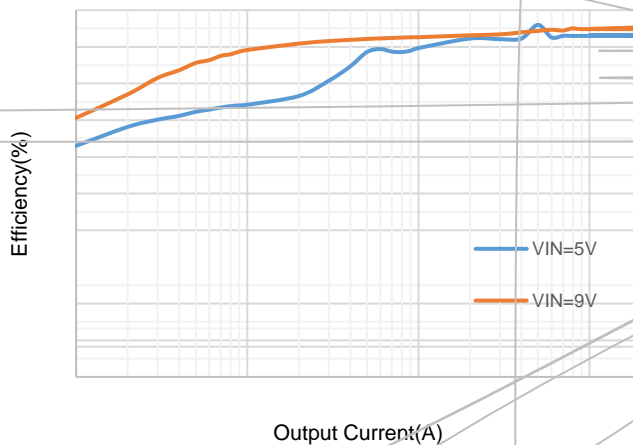

Figure 5. Efficiency vs Load Current, Boost, VOUT=12V

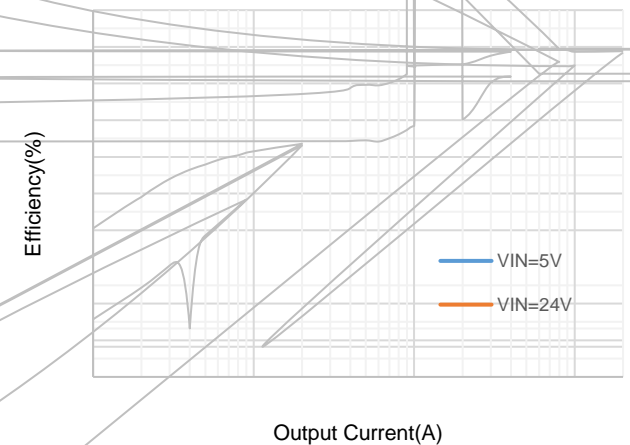

Figure 6. Efficiency vs Load Current, Sepic, VOUT=12V

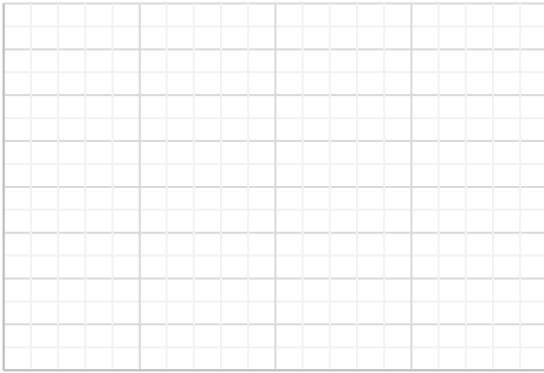

Figure 7. VSENSN vs Input Voltage

Figure 8. DR Volage vs Input Voltage

Figure 9. COMP Current vs Temperature

Figure 10. DR Resistance vs Temperature

Overview

\$

Overvoltage Protection

Slope Compensation Ramp

$$V_{smp} = I_L * R_{SEN} \quad (1)$$

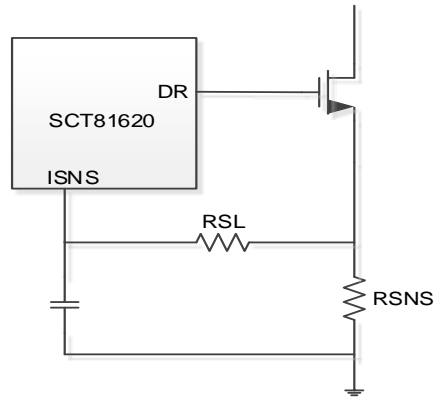

Figure13 .External RSL to increase slope compensation

Adjustable Peak Current Limit

Output Voltage

$$R_{FBT} \frac{V_{OUT} - V_{REF}}{V_{REF}} R_{FBB} \quad (12)$$

where:

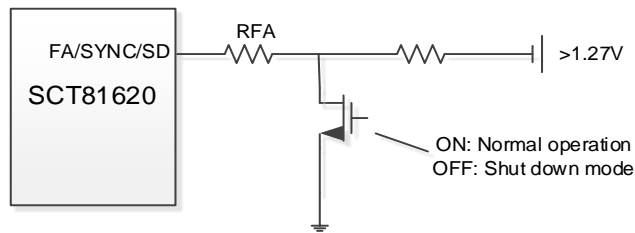

Figure17. Shutdown operation in Frequency Adjust Mode

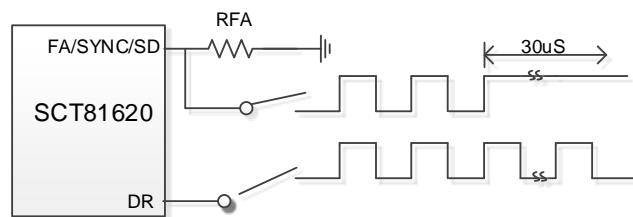

Figure18. Shutdown operation in Frequency Synchronization Mode

Typical Application (Boost)

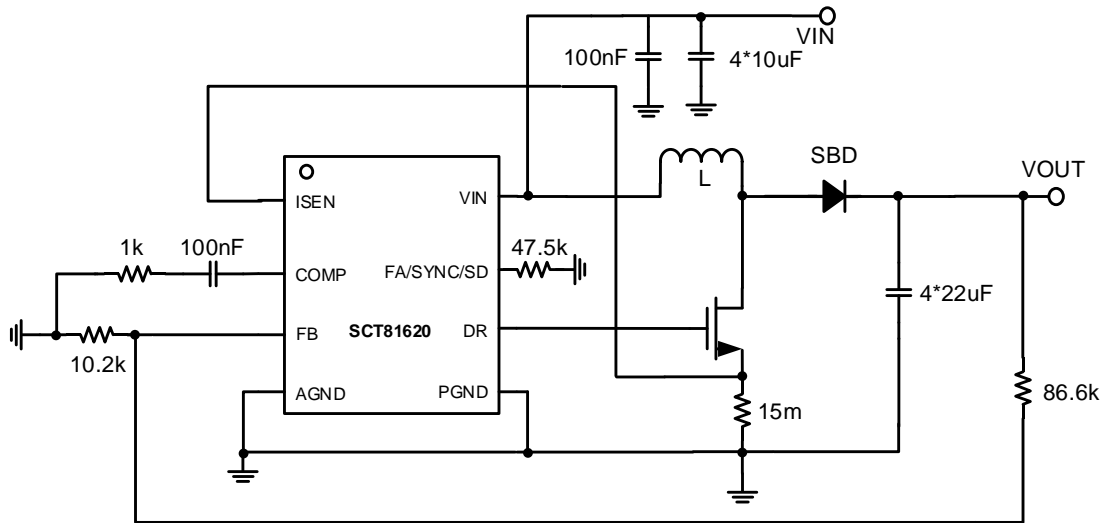

Figure 19. Application Schematic, 3V to 11V, 2A Boost Regulator at 400kHz

Design Parameters

Design Parameters	Example Value
Input Voltage	5V Normal 3V to 11V
Output Voltage	12V
Maximum Output Current	3A
Switching Frequency	400

Where

I_G is the gate drive current.

Output Diode Selection

$$I_{D(PEAK)} = \frac{I_{OUT}}{(1 - D)} \quad I_L \quad (24)$$

SCT81620

Application Waveforms

$V_{in}=5V$, $V_{out}=12V$, unless otherwise noted

Figure 20. Power up(Iload=2A)

Figure 21. Power down(Iload=2A)

Figure 22. Over current protection (Iload=5A)

Figure 23. Over

Typical Application (Sepic)

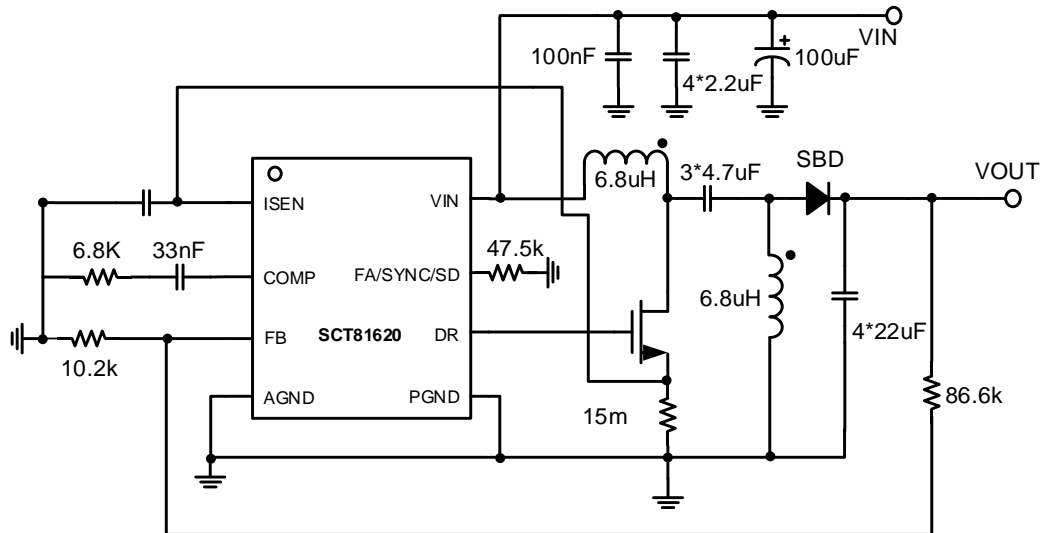

Figure 26. Application Schematic, 5V to 50V, 2A Sepic Regulator at 400kHz

Design Parameters

Design Parameters

Inductor Selection (Sepic)

$$I_{L1} = I_{IN} \cdot 40\% = I_O \cdot \frac{V_O}{V_{IN_MIN}} \cdot 40\% \quad (25)$$

$$(26)$$

$$(27)$$

f_{SW} is the switching frequency.

$$I_{L1_PEAK} = I_{IN} \cdot \frac{I_L}{2} = I_O \cdot \frac{V_O}{V_{IN_MIN}} \cdot \left(1 + \frac{40\%}{2}\right) \quad (28)$$

$$I_{L2_PEAK} = I_O \cdot \frac{I_L}{2} = I_O \cdot \left(1 + \frac{40\%}{2}\right) \quad (29)$$

$$L_1 = L_2 = \frac{L}{2} = \frac{V_{IN_MIN}}{I_L \cdot f_{SW}} \cdot D_{MAX} \quad (30)$$

Power MOSFET Selection

$$V_{SW_PEAK} = V_{IN} + V_O + V_D \quad (31)$$

$$I_{Q_PEAK} = I_{L1_PEAK} + I_{L2_PEAK} \quad (32)$$

$$I_{Q_RMS} = I_O \cdot \sqrt{\frac{V_O \cdot V_{IN_MIN} + V_D \cdot V_O + V_D}{V_{IN_MIN}^2}} \quad (33)$$

$$P_{DIS} = I_{Q_RMS}^2 \cdot R_{DS_ON} \cdot D_{MAX} + V_O \cdot V_{IN_MIN} \cdot I_{Q_PEAK} \cdot \frac{Q_g \cdot f_{SW}}{I_G} \quad (34)$$

I_G is the gate drive current.

Output Diode Selection

$$V_{D_PEAK} \quad V_{IN_MAX} \quad V_{O_MAX} \quad (35)$$

Coupling Capacitor Selection

$$V_{CS} = \frac{I_O \cdot D_{MAX}}{C_S \cdot f_{SW}} \quad (36)$$

$$C_{S_RMS} = O \cdot \sqrt{\frac{O \cdot D}{IN_MIN}} \quad (37)$$

Application Waveforms

Vin=5V, Vout=12V, unless otherwise noted



Figure 28. Power up(Iload=2A)

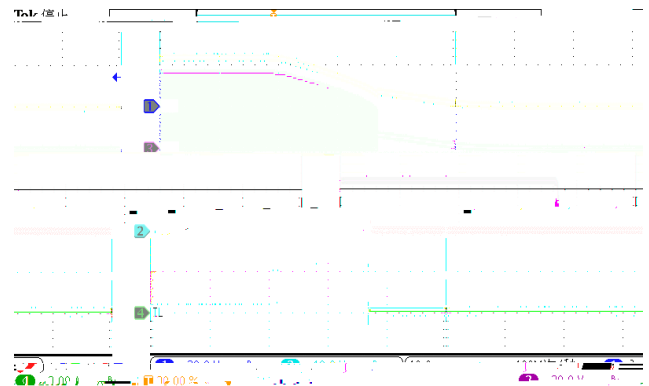

Figure 29. Power down(Iload=2A)



Figure 30. Shutdown remove

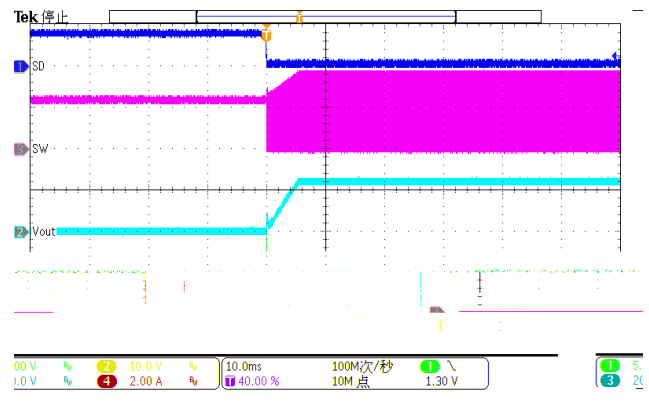

Figure 31. Shutdown remove

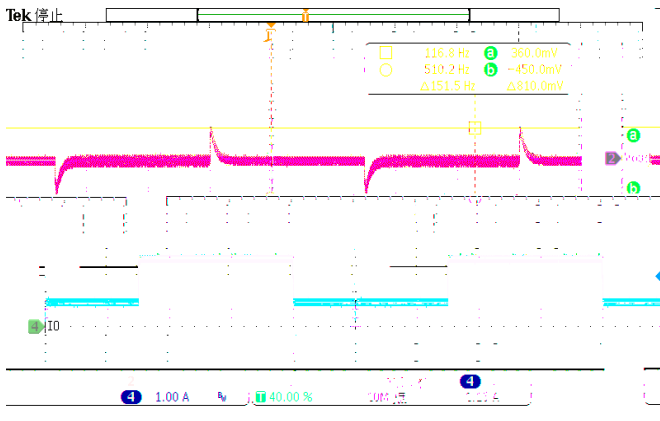

Figure 32. LoadTrans (Iload=0.5A-1.5A)

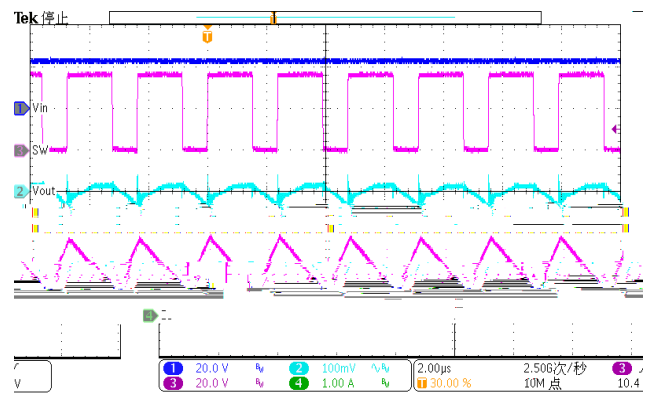
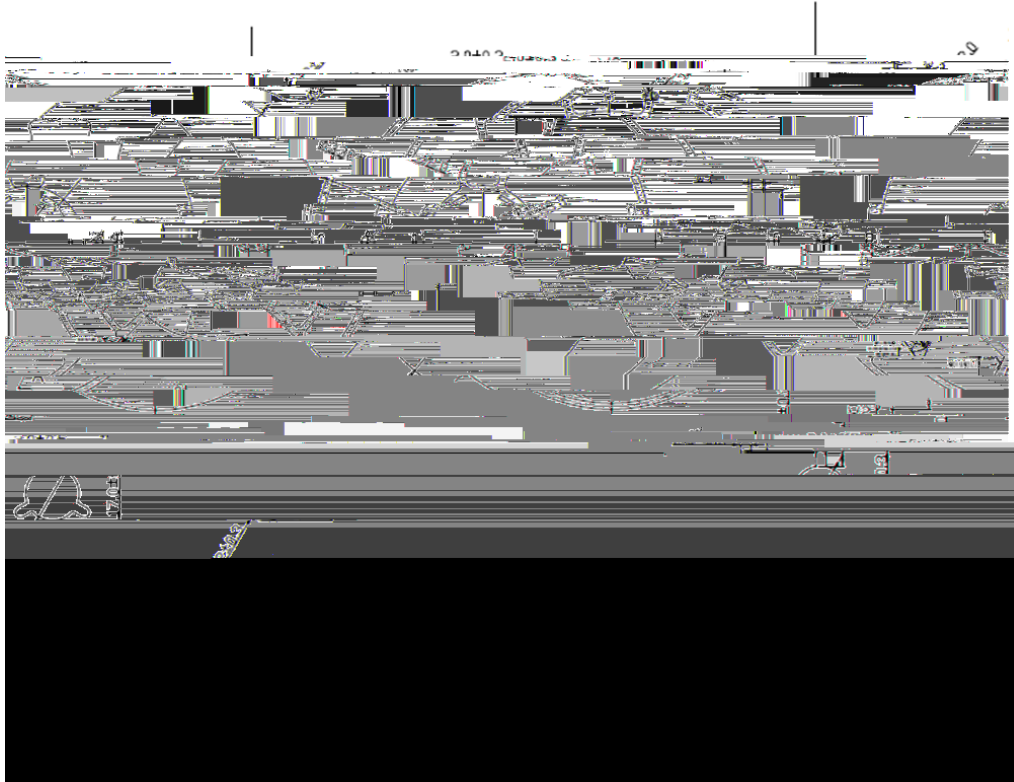

Figure 33. steady-state (Iload=2A)

Layout Guideline



Figure 34. BOOST PCB Layout



NOTICE: The information in this document is subject to change without notice. Users should warrant and guarantee the third party Intellectual Property rights are not infringed upon when integrating Silicon Content Technology (SCT) products into any application. SCT will not assume any legal responsibility for any said applications.